

ITR-9 | ELECTRONIC FAN SPEED CONTROLLER

Mounting and operating instructions

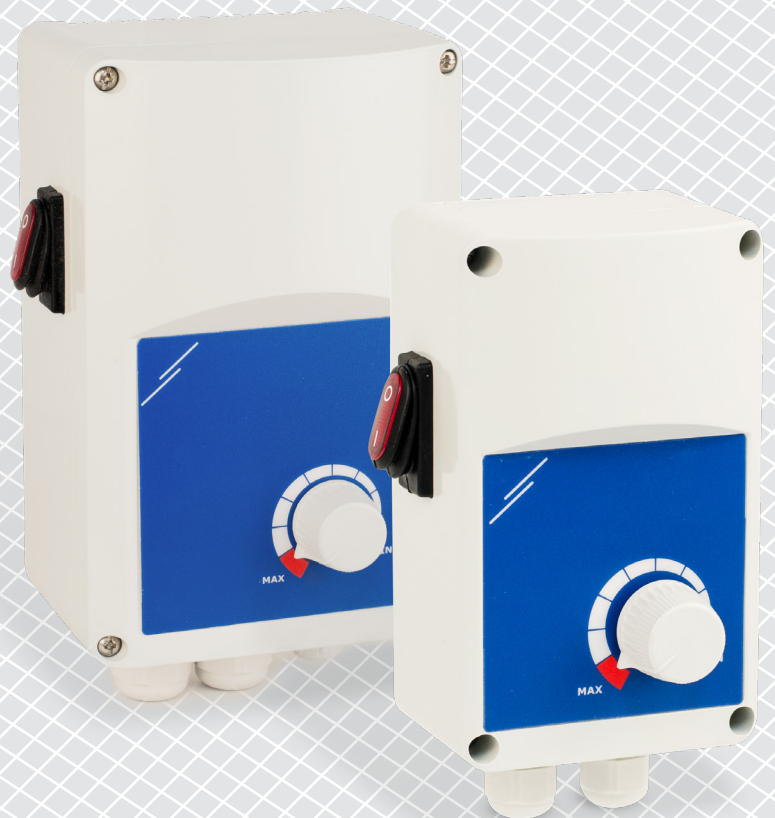

Table of contents

SAFETY AND PRECAUTIONS	3
PRODUCT DESCRIPTION	4
ARTICLE CODES	4
INTENDED AREA OF USE	4
TECHNICAL DATA	4
STANDARDS	4
WIRING AND CONNECTIONS	5
OPERATIONAL DIAGRAMS	5
MOUNTING INSTRUCTIONS IN STEPS	5
VERIFICATION OF INSTALLATION	7
TRANSPORT AND STORAGE	7
WARRANTY AND RESTRICTIONS	7
MAINTENANCE	7

SAFETY AND PRECAUTIONS



Read all the information, the datasheet, Modbus map, mounting and operating instructions and study the wiring and connection diagram before working with the product. For personal and equipment safety, and for optimum product performance, make sure you entirely understand the contents before installing, using or maintaining this product.



For safety and licensing (CE) reasons, unauthorised conversion and /or modifications of the product are inadmissible.



The product should not be exposed to abnormal conditions, such as extreme temperatures, direct sunlight or vibrations. Long-term exposure to chemical vapours in high concentration can affect the product performance. Make sure the work environment is as dry as possible; avoid condensation.



All installations shall comply with local health and safety regulations and local electrical standards and approved codes. This product can only be installed by an engineer or a technician who has expert knowledge of the product and safety precautions.



Avoid contacts with energised electrical parts. Always disconnect the power supply before connecting, servicing or repairing the product.



Always verify that you apply appropriate power supply to the product and use appropriate wire size and characteristics. Make sure that all the screws and nuts are well tightened and fuses (if any) are fitted well.



Recycling of equipment and packaging should be taken into consideration and these should be disposed of in accordance with local and national legislation / regulations.



In case there are any questions that are not answered, please contact your technical support or consult a professional.

PRODUCT DESCRIPTION

The ITR-9 series of electronic fan speed controllers regulate the speed of single-phase (110–240 VAC / 50–60 Hz) voltage controllable motors by varying the supplied voltage. The ITR-9 controllers provide automatic power supply detection. The minimum speed is adjusted via an internal trimmer. The output is regulated by a potentiometer in the range between the minimum output voltage and the supply voltage. The series features an unregulated output for connecting a valve, lamp, damper, etc. There are two start-up modes - kick start and soft start, selectable via a jumper.

ARTICLE CODES

Code	Rated max. current, [A]	Fuse rating, [A]
ITR-9-15-DT	1,5	F-3,15 A-H 250 VAC
ITR-9-30-DT	3,0	F-5,00 A-H 250 VAC
ITR-9-50-DT	5,0	F-8,00 A-H 250 VAC
ITR-9-60-DT	6,0	(6,3*32) F-10,00 A-H 250 VAC
ITR-9100-DT	10,0	(6,3*32) F-16,00 A-H 250 VAC

INTENDED AREA OF USE

- Fan speed control of voltage controllable motors in ventilation systems
- For indoor use only

TECHNICAL DATA

- Power supply (Us): 110–240 VAC / 50–60 Hz
- Regulated output: max. current rating depends on the selected version
- Unregulated output, L1: I_{max}. 2 A
- Min. voltage output (MIN): 30–60 % of Us, selectable by trimmer
- Kick start or soft start, selectable by jumper on the PCB
- Kick start duration: 8–10 seconds
- ON/OFF switch
- Enclosure:
 - ▶ plastic R-ABS, UL94-V0
 - ▶ grey colour (RAL 7035)
- Protection standard: IP54 (according to EN 60529)
- Operating ambient conditions:
 - ▶ temperature: -20–35°C
 - ▶ relative humidity: 5–95 % rH (non-condensing)
- Storage temperature: -40–50°C

STANDARDS

- Low Voltage Directive 2014/35/EU CE
- EMC 2014/30/EU:
 - ▶ EN 61000-6-2: 2005 Electromagnetic compatibility (EMC) - Part 6-2: Generic standards - Immunity for industrial environments. Amendment AC:2005,
 - ▶ EN 61000-6-3:2007 Electromagnetic compatibility (EMC) - Generic standards. Emission standard for equipment in residential environments. Amendment A1:2011 and AC:2012
 - ▶ EN 61326-2-3:2013 Electrical equipment for measurement, control and laboratory use - EMC requirements - Part 2-3: Particular requirements - Test configuration, operational conditions and performance criteria for transducers with integrated or remote signal conditioning
- RoHs Directive 2011/65/EU

WIRING AND CONNECTIONS

L	Power supply, 110–240 VAC / 50–60 Hz
N	Neutral
L1	Unregulated output, I _{max} . 2 A
PE	Earth terminal
U2	Regulated output to the motor - line
U1	Regulated output to the motor - neutral
Connections	Cable cross section: max. 2,5 mm ² ; Cable gland clamping range: 5–10 mm

OPERATIONAL DIAGRAMS

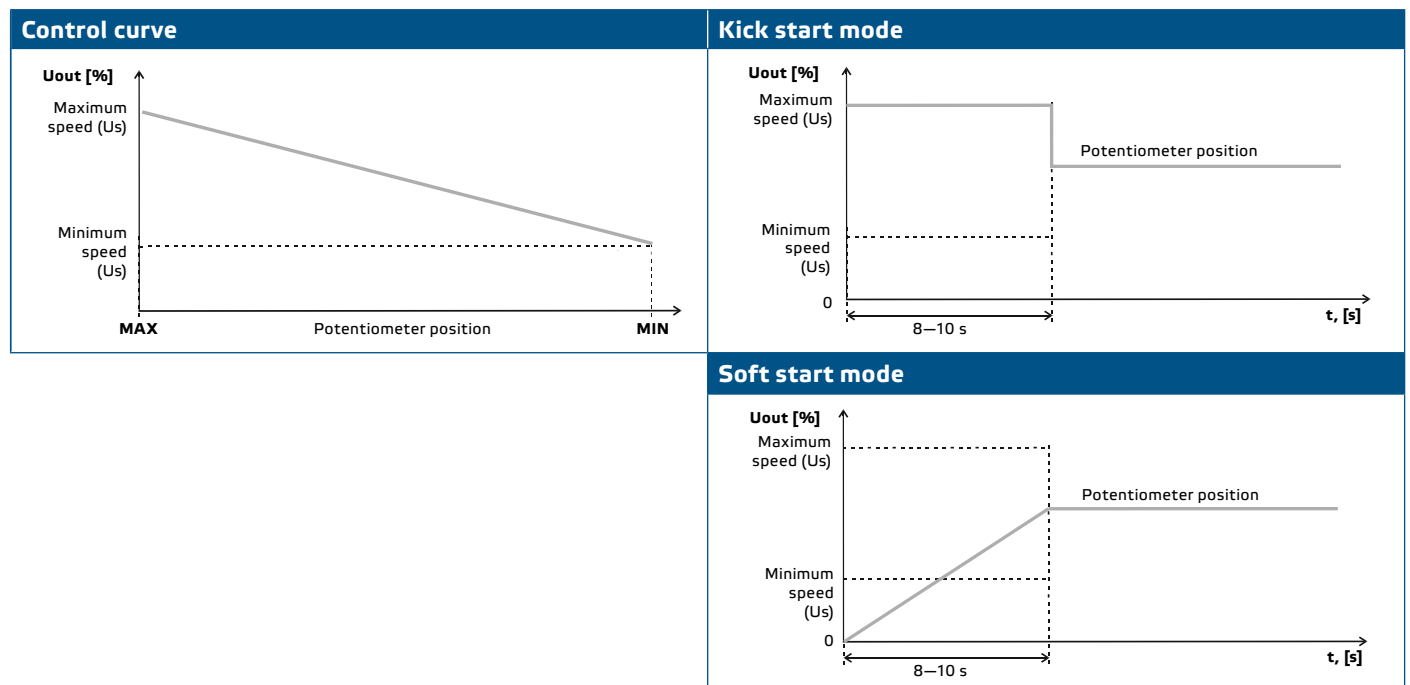

ATTENTION

To disable the ON / OFF switch position (1,5 A and 3,0 A versions ONLY!) connect the 230 VAC supply voltage to the unregulated output (L1). In this case, do not connect the power supply to L.

MOUNTING INSTRUCTIONS IN STEPS

Before you start mounting the unit read carefully **“Safety and Precautions”**. Choose a smooth surface for installation (a wall, panel, etc.).

Follow these steps:

1. Make sure that the controller is switched off.
2. Unscrew the front cover and open the enclosure. Mind the wires that connect the potentiometer with the printed circuit board.
3. Fix the unit to the wall or panel using the provided screws and dowels. Mind the correct mounting position and unit mounting dimensions. (See **Fig.1 Mounting dimensions** and **Fig. 2 Mounting position**).

Fig. 1 Mounting dimensions

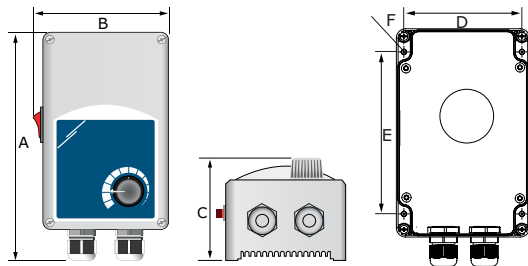

Article code	A	B	C	D	E	F
ITR-9-15-DT ITR-9-30-DT	162 mm	96 mm	75 mm	71 mm	108,8 mm	Ø 4,2
ITR-9-50-DT	162 mm	96 mm	93 mm	71 mm	108,8 mm	Ø 4,2
ITR-9-60-DT ITR-9100-DT	205 mm	124 mm	97 mm	102 mm	140 mm	Ø 4,6

Fig. 2 Mounting position

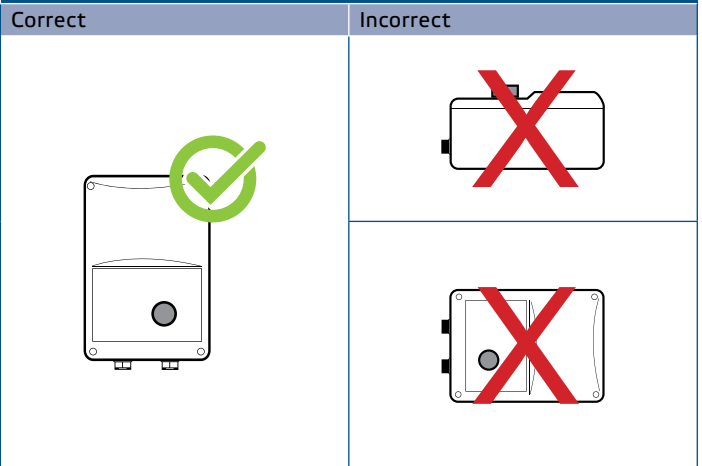

- Insert the cables through the cable glands and do the wiring according to the wiring diagram (see **Fig.3**) while adhering to the information from section **"Wiring and connections"** above.
 - Connect the motor / fan (terminals U2, U1 and PE);
 - Connect the power supply terminals (L and N);
 - If applicable, connect the unregulated output (L1 and N). It can be used to supply a 230 VAC valve, lamp, etc.

Fig. 3 Wiring and connections

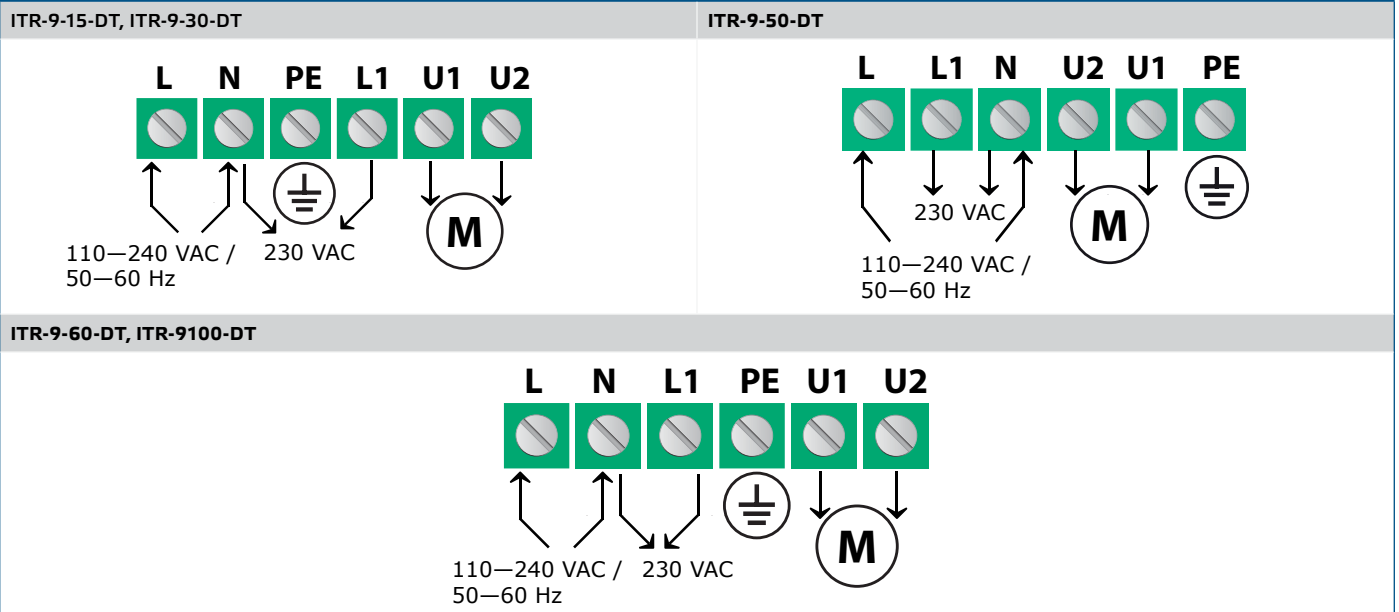

ATTENTION

Make sure that the connections are correct before you power the unit and you use cables with appropriate diameter.

- Adjust the minimum speed via the trimmer (if necessary). The factory preset is 45 % of Us. See **Fig.4 Min. speed trimmer**.
- Select kick start or soft start using the jumper shown in **Fig.5**. The factory setting is "Kick start enabled", to disable it - remove the jumper. Both kick start and soft start duration times are fixed (8–10 seconds).

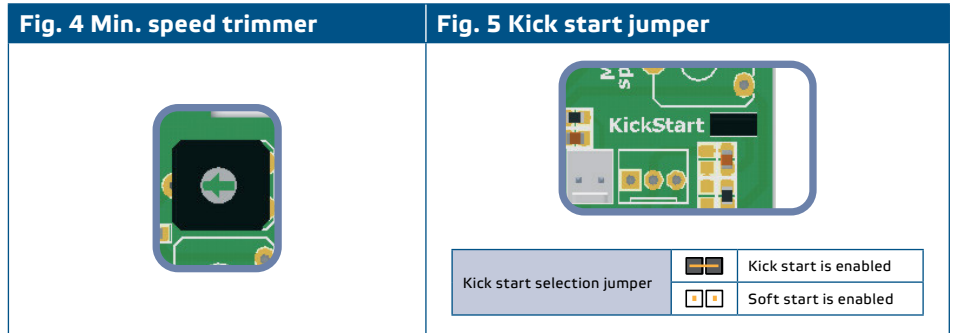

(indicates closed position of the jumper.)

7. Put back the cover and secure it with the screws. Tighten the cable glands.
8. Switch on the power supply.

VERIFICATION OF INSTALLATION

ATTENTION

Use only tools and equipment with non-conducting handles when working on electrical devices.

Make sure that if "Kick start" is enabled, the motor runs at maximum speed for 8–10 seconds. After this time, it will run according to the potentiometer position. If "Soft start" is enabled, the motor goes from minimum speed to the speed selected by the potentiometer during the first 8–10 seconds. If this is not the case, check the connections and the settings again.

TRANSPORT AND STORAGE

Avoid shocks and extreme conditions; stock in original packaging.

WARRANTY AND RESTRICTIONS

ATTENTION

Use only fuses of a type and rating specified above; otherwise, loss of warranty will ensue.

Two years from the delivery date against defects in manufacturing. Any modifications or alterations to the product after the date of publication relieve the manufacturer of any responsibilities. The manufacturer bears no responsibility for any misprints or mistakes in this data.

MAINTENANCE

In normal conditions, this product is maintenance-free. If soiled, clean with a dry or damp cloth. In case of heavy pollution, clean with a non-aggressive product. In these circumstances, the unit should be disconnected from the supply. Pay attention that no fluids enter the unit. Only reconnect it to the supply when it is completely dry.

